

V17 20X50

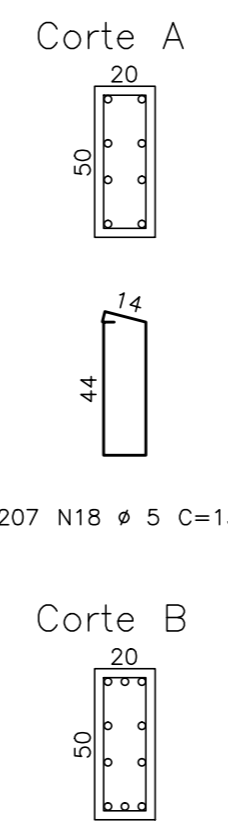

V18 20X50

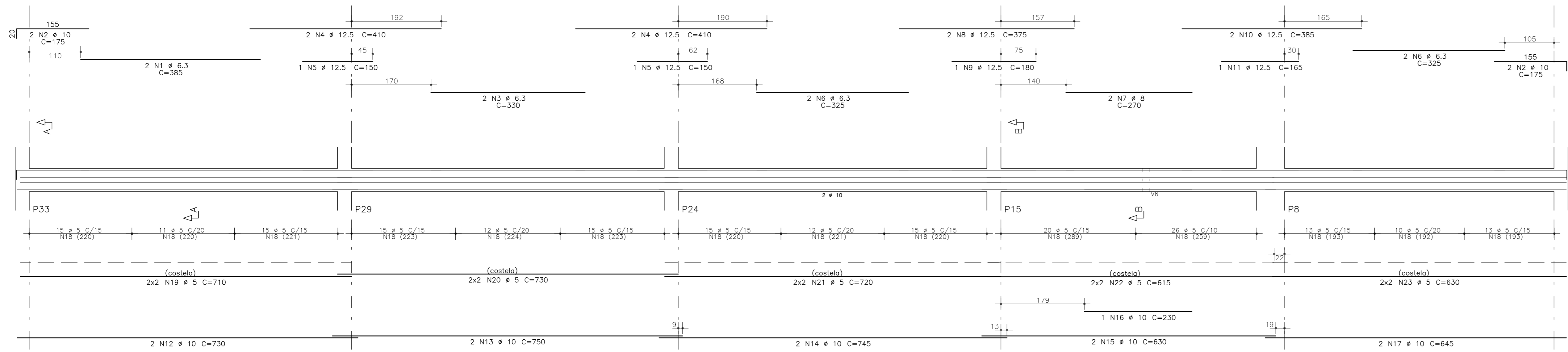
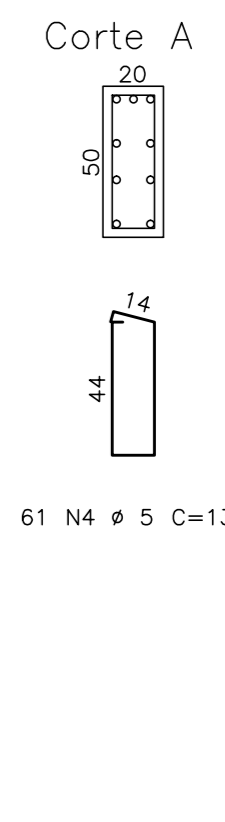
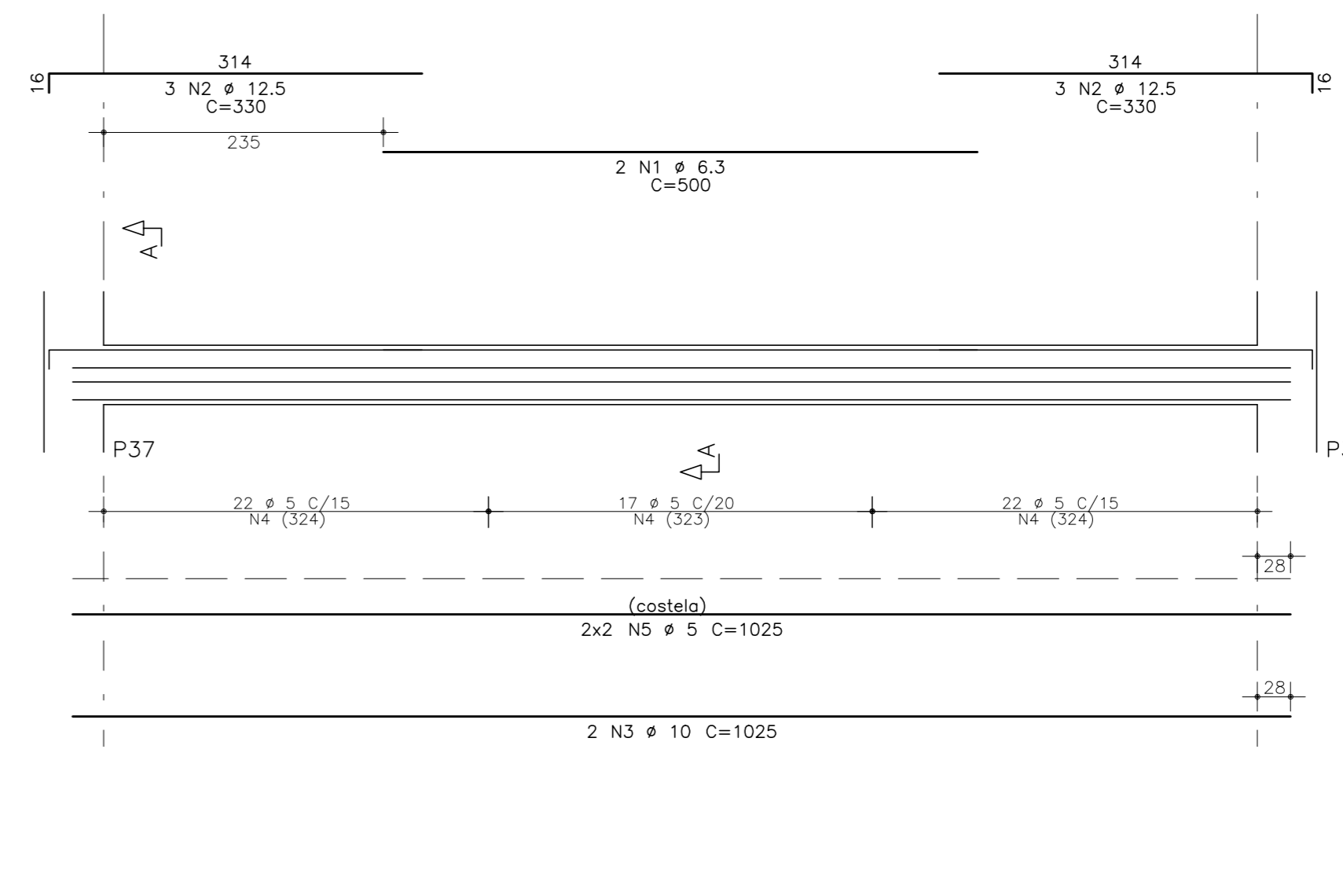

V19 20X50

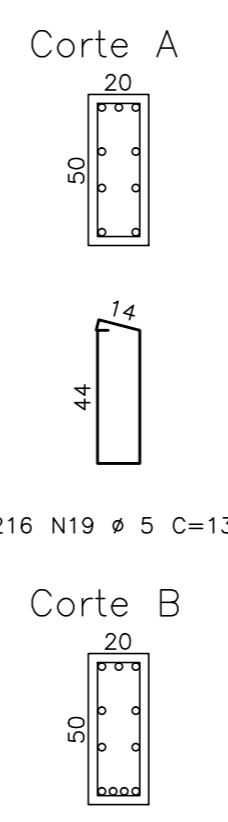
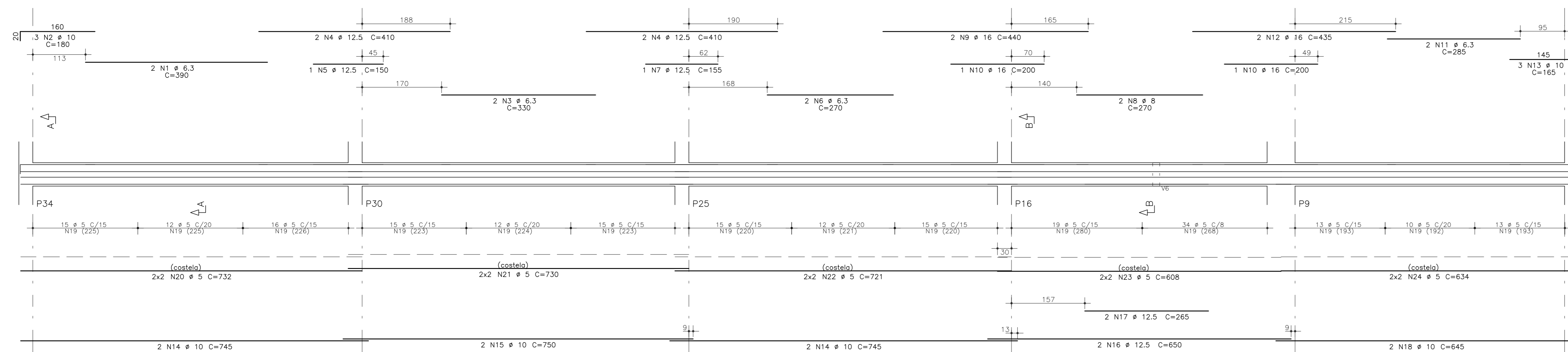

V20=V25 15X50

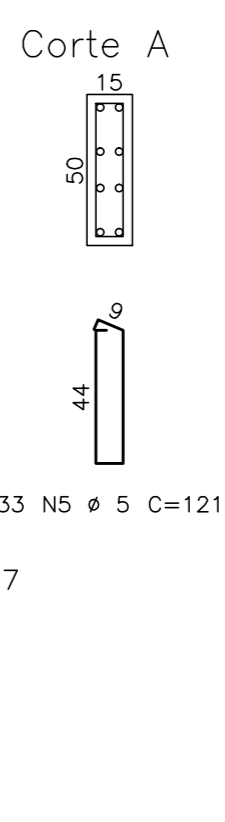
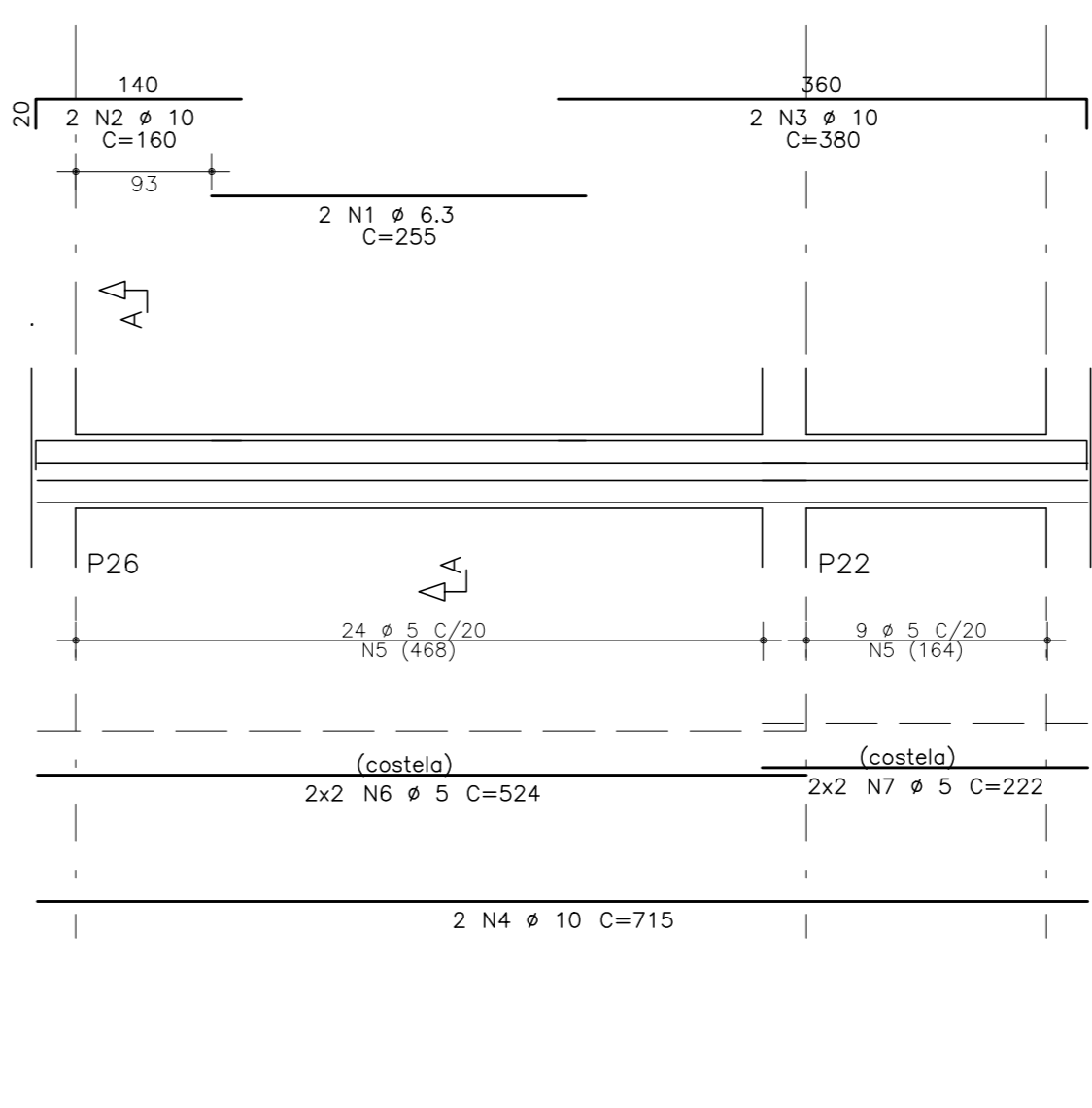

V21=V24 15X145

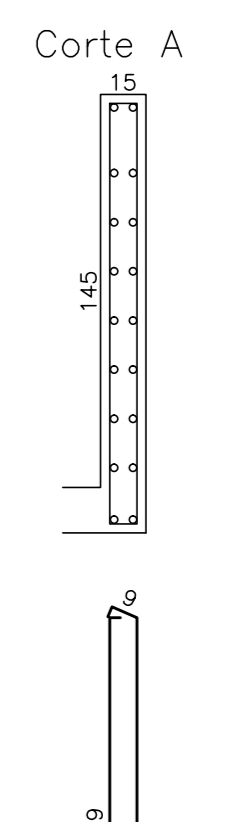
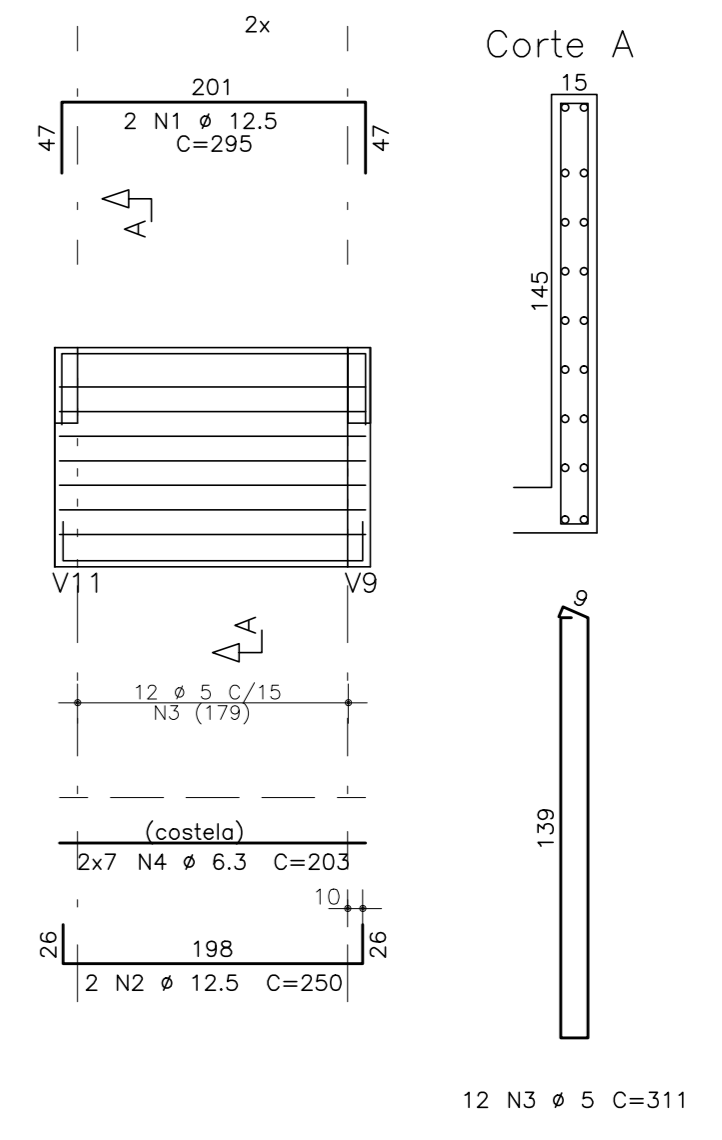

ATENÇÃO:
- A VIG V22 FOI ELIMINADA NO DESENVOLVIMENTO DO PROJETO.

V23 20X50

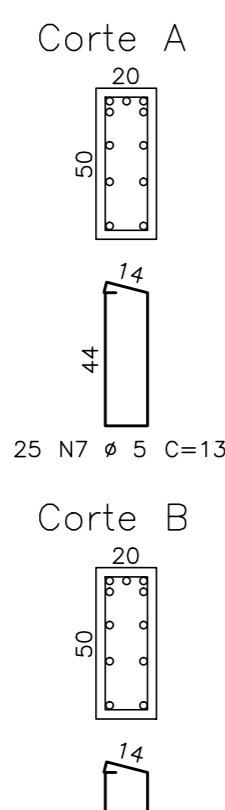
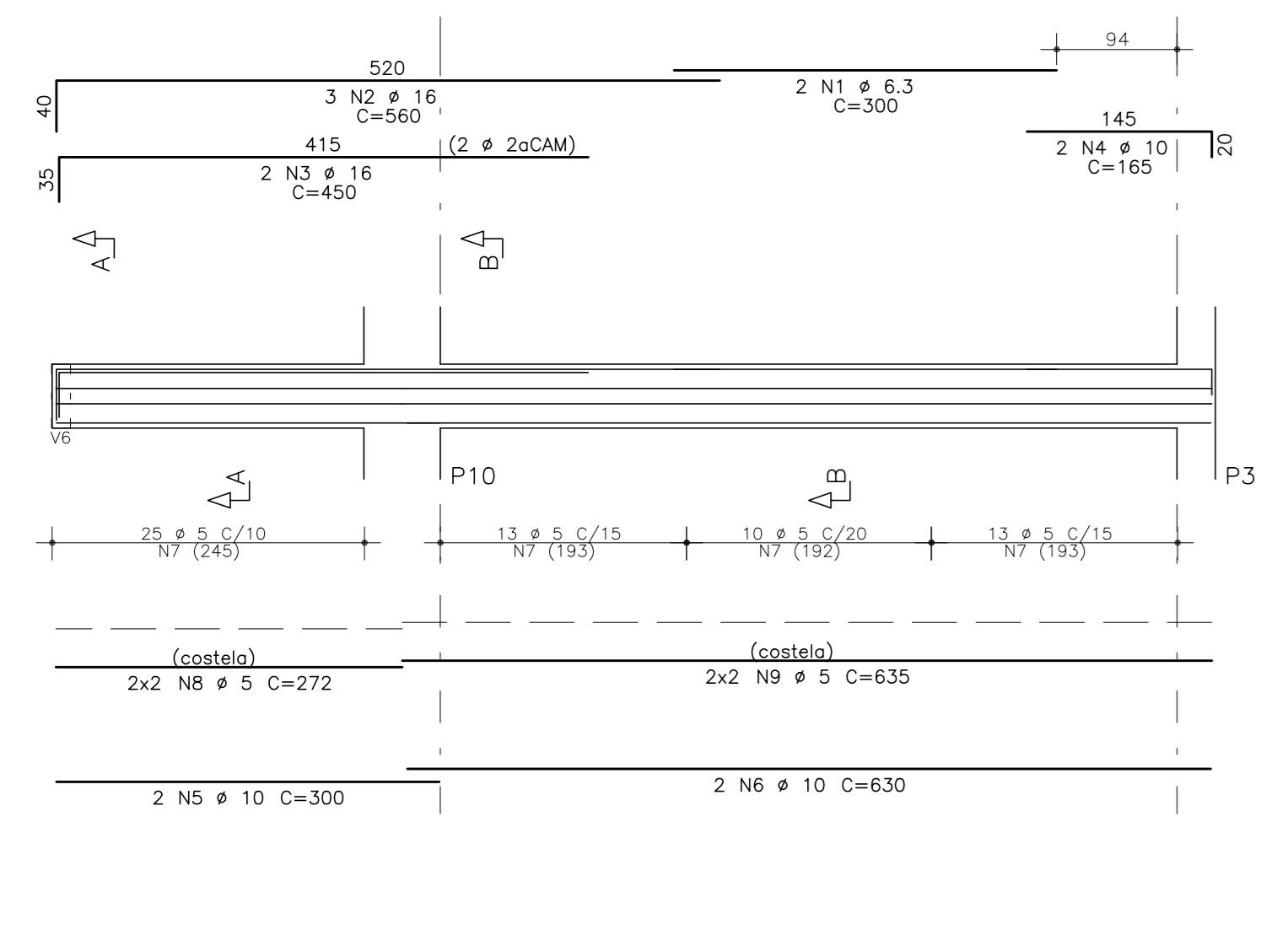

V27 20X50

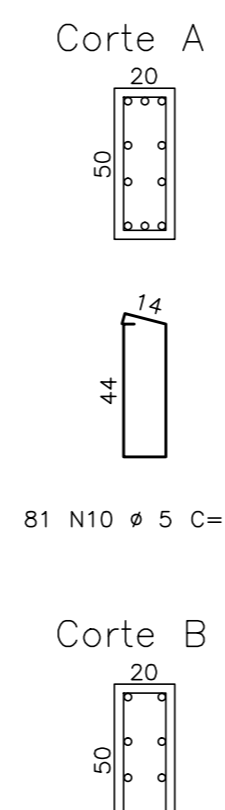
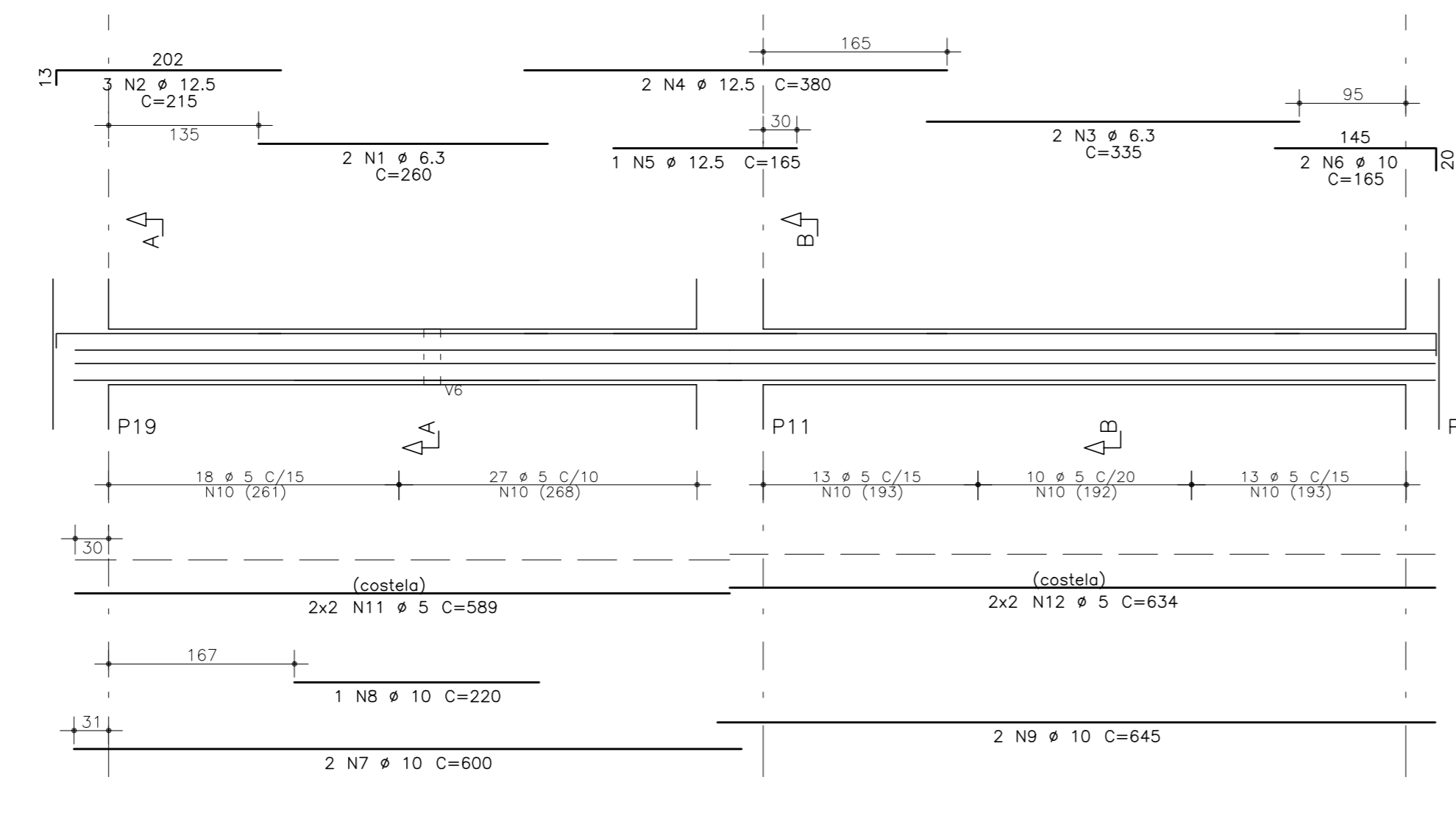

V28 20X50

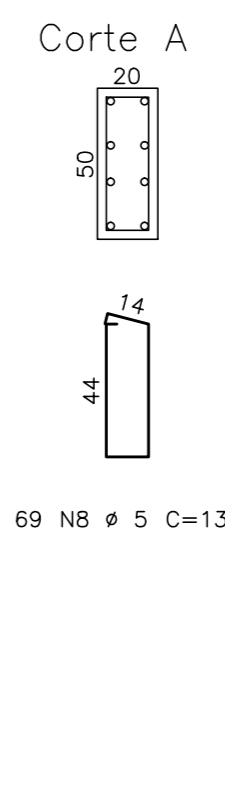
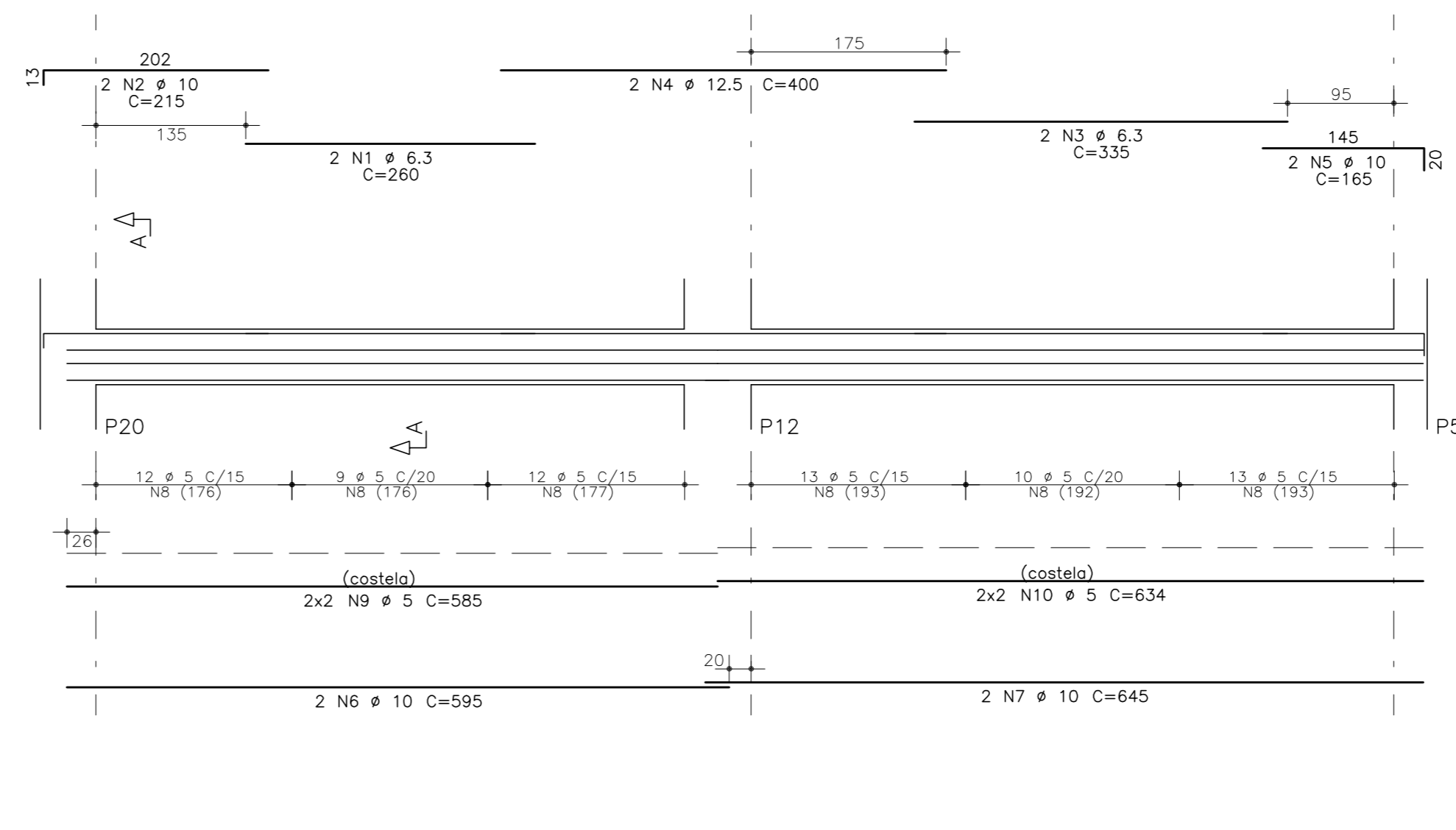

V30 15X40

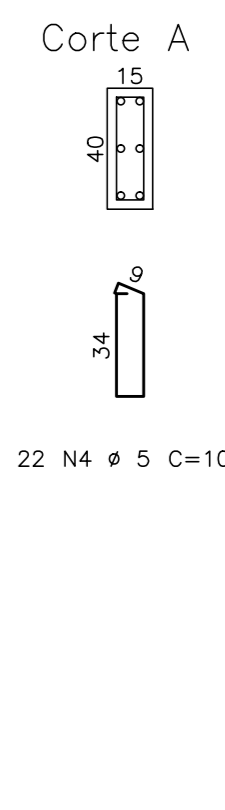
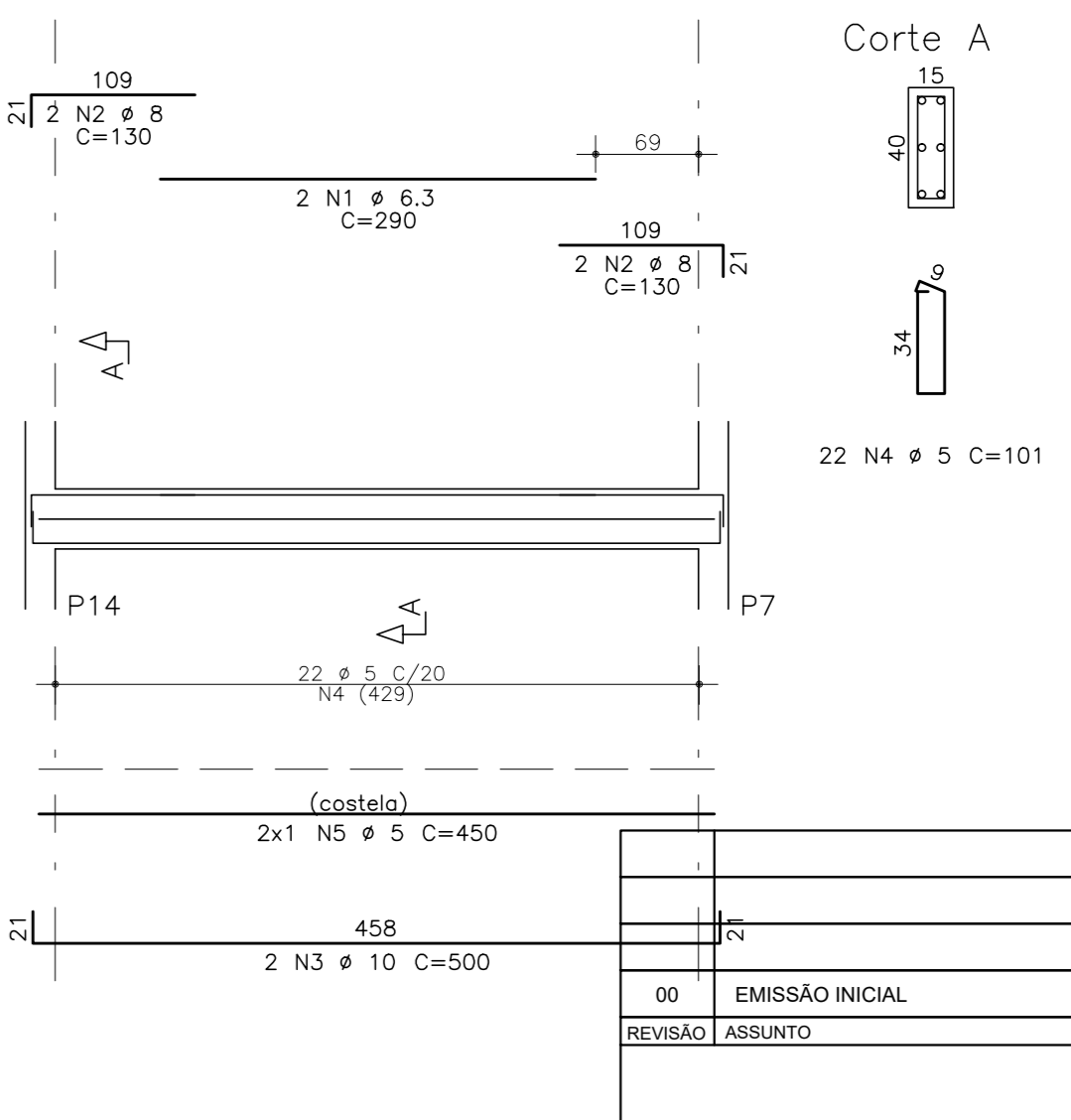

V26 20X50

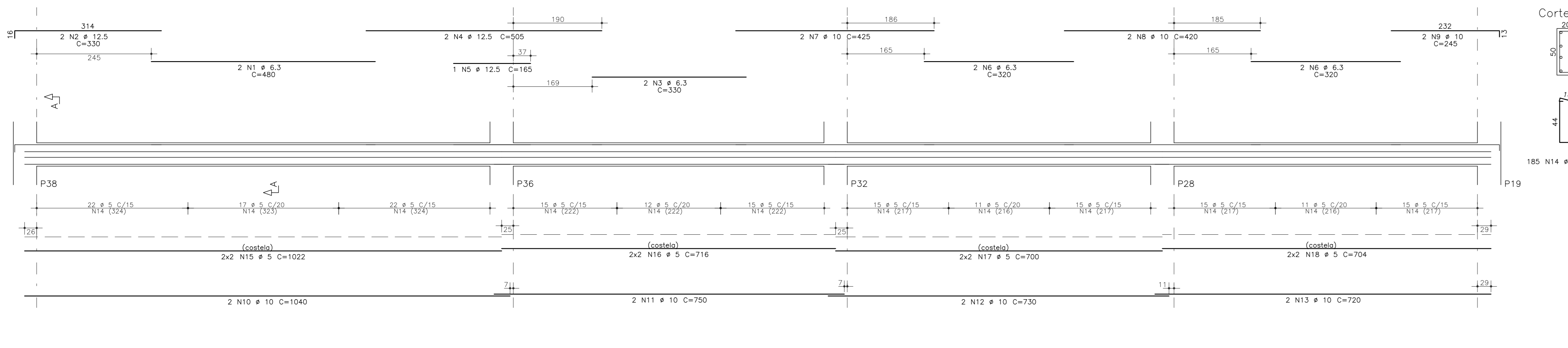

V29 20X50

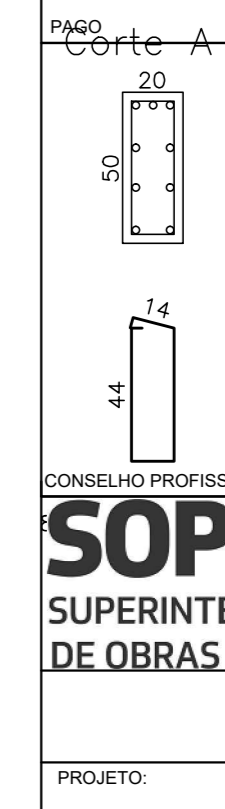
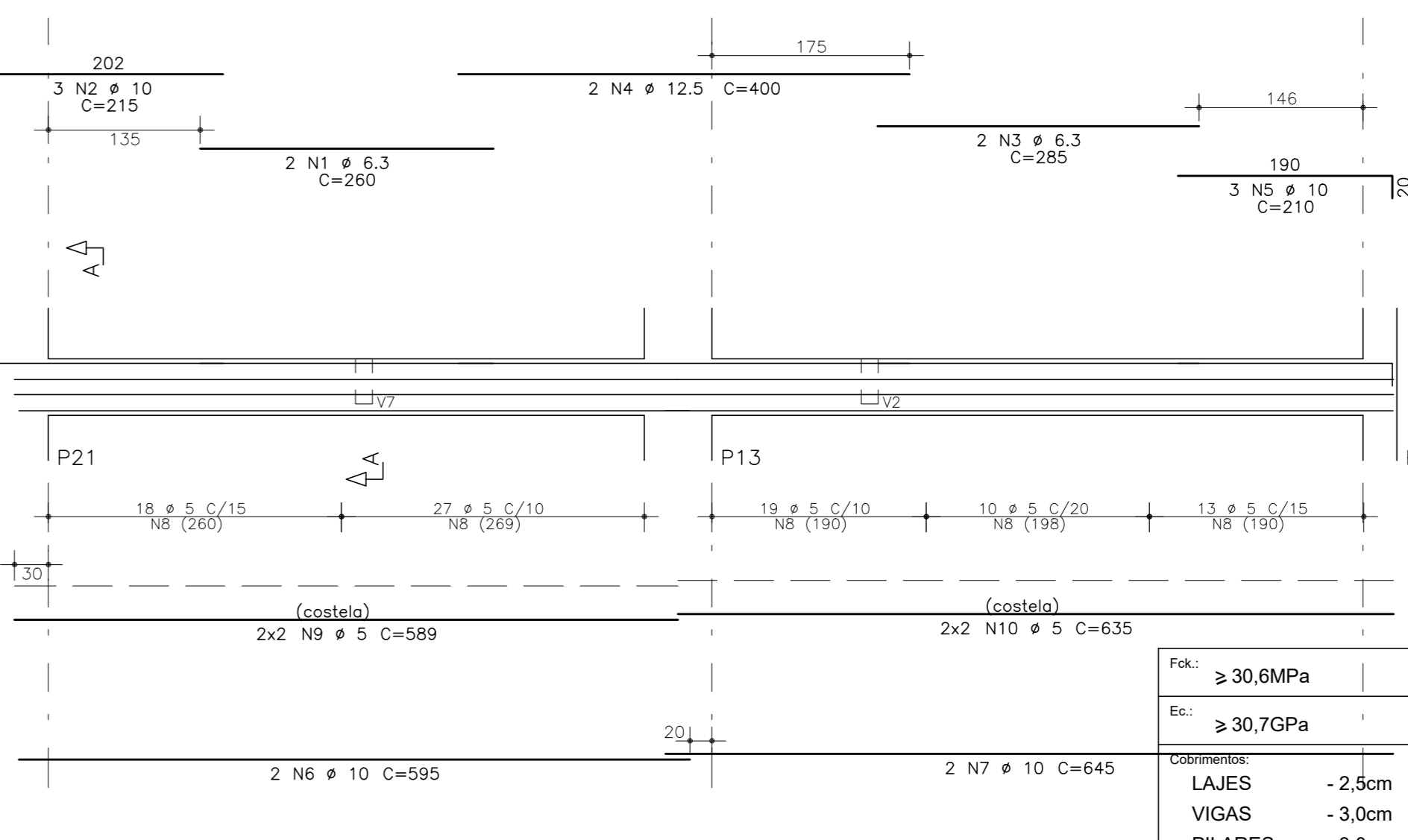

ÁÇO	POS	BIT	QUANT	COMPRIMENTO (cm)	UNID	TOTAL (cm)
V17						
S0A	1	6.3	2	385	770	
S0A	2	12.5	2	115	230	
S0A	3	6.3	3	330	990	
S0A	4	12.5	4	410	1640	
S0A	5	12.5	5	150	300	
S0A	6	6.3	3	180	540	
S0A	7	8	8	270	540	
S0A	8	12.5	8	315	630	
S0A	9	12.5	5	165	330	
S0A	10	12.5	5	385	770	
S0A	11	12.5	5	165	330	
S0A	12	10	5	730	1460	
S0A	13	10	5	165	330	
S0A	14	10	7	745	1490	
S0A	15	10	5	645	1290	
S0A	16	10	5	230	230	
S0A	17	10	5	645	1290	
S0B	18	5	20	131	2717	
S0B	19	5	5	710	2840	
S0B	20	5	5	730	2920	
S0B	21	5	5	720	2880	
S0B	22	5	5	615	2460	
S0B	23	5	5	630	2520	
V18						
S0A	1	6.3	2	500	1000	
S0A	2	12.5	2	330	660	
S0A	3	10	2	1025	2050	
S0B	4	5	61	131	7991	
S0B	5	5	6	1025	6150	
V19						
S0A	1	6.3	3	390	780	
S0A	2	10	3	180	540	
S0A	3	12.5	3	330	660	
S0A	4	12.5	4	410	1640	
S0A	5	6.3	3	180	540	
S0A	6	12.5	5	155	300	
S0A	7	12.5	5	155	300	
S0A	8	6.3	3	270	540	
S0A	9	16	4	440	880	
S0A	10	16	5	230	460	
S0A	11	6.3	3	285	570	
S0A	12	16	4	425	850	
S0A	13	10	4	425	850	
S0A	14	10	4	745	1490	
S0A	15	10	5	750	1500	
S0A	16	12.5	5	650	1300	
S0A	17	12.5	5	265	530	
S0A	18	10	5	645	1290	
S0B	19	5	212	131	28296	
S0B	20	5	5	732	2928	
S0B	21	5	5	730	2920	
S0B	22	5	5	721	2884	
S0B	23	5	5	608	2432	
S0B	24	5	5	634	2536	
V20=V25						
S0A	1	6.3	4	255	1020	
S0A	2	10	4	160	640	
S0A	3	10	3	380	1520	
S0A	4	10	5	715	2860	
S0B	5	5	64	131	7986	
S0B	6	5	5	412	2060	
S0B	7	5	5	222	1110	
V21=V24						
S0A	1	12.5	4	295	1180	
S0A	2	10	4	160	640	
S0A	3	5	24	311	7464	
S0A	4	6.3	28	293	5684	
V23						
S0A	1	6.3	3	300	600	
S0A	2	10	3	160	640	
S0A	3	16	4	450	900	
S0A	4	10	3	165	660	
S0A	5	10	3	300	900	
S0A	6	10	5	630	1575	
S0B	7	5	61	131	7991	
S0B	8	5	5	272	1088	
S0B	9	5	5	635	2540	
V26						
S0A	1	6.3	3	480	960	
S0A	2	12.5	3	330	660	
S0A	3	6.3	3	330	660	
S0A	4	12.5	5	505	1010	
S0A	5	12.5	5	165	330	
S0A	6	6.3	3	420	840	
S0A	7	10	4	425	850	
S0A	8	10	5	245	490	
S0A	9	10	5	1040	2080	
S0A	10	10	5	750	1500	
S0A	11	10	5	730	1460	
S0A	12	10	5	720	1440	
S0A	13	10	5	181	362	
S0B	14	5	181	1022	4089	
S0B	15	5	5	716	2864	
S0B	16	5	5	700	2800	
S0B	17	5	5	704	2816	
S0B	18	5	5	704	2816	
V27						
S0A	1	6.3	3	260	520	
S0A	2	12.5	3	215	430	
S0A	3	10	3	330	660	
S0A	4	12.5	3	380	760	
S0A	5	10	3	165	330	
S0A	6	10	3	165	330	
S0A	7	10	5	600	1200	
S0A	8	10	5	220	440	
S0A	9	10	5	645	1290	
S0B	10	5	61	131	10611	
S0B	11	5	5	589	2356	
S0B	12	5	5	634	2536	
V28						
S0A	1	6.3	3	260	520	
S0A	2	12.5	3	215	430	
S0A	3	10	3	330	660	
S0A	4	12.5	3	380	760	
S0A	5	10	3	165	330	
S0A	6	10	3	165	330	
S0A	7	10	5	600	1200	
S0A	8	10	5	220	440	
S0A	9	10	5	645	1290	
S0B	10	5	61	131	10611	
S0B	11	5	5	589	2356	
S0B	12	5	5	634	2536	
V29						
S0A	1	6.3	3	260	520	
S0A	2	10	3	215	430	
S0A	3	12.5	3	330	660	
S0A	4	12.5	3	380	760	
S0A	5	10	3	165	330	
S0A	6	10	3	165	330	
S0A	7	10	5	600	1200	
S0A	8	10	5	220	440	
S0A	9	10	5	645	1290	
S0B	10	5	61	131	10611	
S0B	11	5	5	589	2356	
S0B	12	5	5	634	2536	
V30						
S0A	1	6.3	3	290	580	
S0A	2	10	3	130	260	
S0A	3	10	5	500	1000	
S0B	4	5	22	101	2222	
S0B	5	5	5	450	900	

ÁÇO	RESUMO	ÁÇO	CA	SO-60	PESO
	(mm)			(kg)	(kg)
608	5	2	135	270	279
S0A	6	3	205	615	50
S0A	8	8	16	730	57
S0A	10	10	437	270	1190
S0A	12	12	167	161	161
S0A	16	16	47	75	75
Peso total					329 kg
Peso total					662 kg

01 EMISSÃO INICIAL
REVISÃO ASSINTO

PROJETO: ESCOLA DE ENSINO MÉDIO PADRÃO - TIPO IIESTRUTURA DE CONCRETO ARMADO

INTERESSADO: SEDUC - SECRETARIA DE EDUCAÇÃO

MUNICÍPIO: CEARÁ

AUTOR: RSDO S/N

ETAPA: EXECUTIVO

RESERVA DE PROPRIEDADE INTELECTUAL

PROPRIETÁRIO

PROJETO

CONSTRUÇÃO

CONSELHO PROFISSIONAL

SECRETARIA DAS CIDADES

SECRETARIA DE EDUCAÇÃO

SECRETARIA DE CONCRETO ARMADO

SECRETARIA DE ENGENHARIA

SECRETARIA DE FINANÇAS

SECRETARIA DE INFRAESTRUTURA

SECRETARIA DE PLANEJAMENTO

SECRETARIA DE PROJETOS

SECRETARIA DE RECURSOS HUMANOS

SECRETARIA DE TRIBUTAÇÃO

SECRETARIA DE LOGÍSTICA

SECRETARIA DE COMUNICAÇÃO

SECRETARIA DE CULTURA

SECRETARIA DE ESPORTE

SECRETARIA DE SAÚDE

SECRETARIA DE SEGURANÇA

SECRETARIA DE TURISMO

SECRETARIA DE TRABALHO

SECRETARIA DE TRANSPORTE

SECRETARIA DE URBANISMO

SECRETARIA DE ZONAMENTO

SECRETARIA DE AGRICULTURA

SECRETARIA DE INDÚSTRIA

SECRETARIA DE COMÉRCIO

SECRETARIA DE SERVIÇOS

SECRETARIA DE ENERGIA

SECRETARIA DE SANEAMENTO

SECRETARIA DE HABITACIONAL

SECRETARIA DE MEIO AMBIENTE

SECRETARIA DE PATRIMÔNIO

SECRETARIA DE CULTURA

SECRETARIA DE ESPORTE

SECRETARIA DE SAÚDE

SECRETARIA DE SEGURANÇA

SECRETARIA DE TURISMO

SECRETARIA DE TRABALHO

SECRETARIA DE TRANSPORTE

SECRETARIA DE URBANISMO

SECRETARIA DE ZONAMENTO

SECRETARIA DE AGRICULTURA

SECRETARIA DE INDÚSTRIA

SECRETARIA DE COMÉRCIO

SECRETARIA DE SERVIÇOS

SECRETARIA DE ENERGIA

SECRETARIA DE SANEAMENTO

SECRETARIA DE HABITACIONAL

SECRETARIA DE MEIO AMBIENTE

SECRETARIA DE PATRIMÔNIO

SECRETARIA DE CULTURA

SECRETARIA DE ESPORTE

SECRETARIA DE SAÚDE

SECRETARIA DE SEGURANÇA

SECRETARIA DE TURISMO

SECRETARIA DE TRABALHO

SECRETARIA DE TRANSP